

2024 REAR WINDOW
MOVING IMAGE PROPOSALS
DUNEDIN PUBLIC ART GALLERY

Dunedin Public
Art Gallery

Rear Window

MOVING IMAGE PROGRAMME

Dunedin Public Art Gallery is inviting proposals for the 2024 Rear Window Moving Image Programme. This programme allows artists, existing and emerging, to exhibit moving image works in an open and accessible public gallery setting. Previous artists have included of Aliyah Winter, Christopher Ulutupu, George Watson, Neihana Gordon-Stables, Jae Hoon Lee, Laura Duffy, Louisa Afoa, Pati Solomona Tyrell and Sonya Lacey. **Nau mai, haere mai e hoa. You could be next!**

Successful Applicants will receive a showing fee of \$500
Applications close Rāmere 24 Whiringa-ā-rangi | Friday 24 November 2023

Selected works will be exhibited on a single flatscreen monitor affixed to the wall and will screen 24/7. Due to the neighbouring residents, the audio for Rear Window works runs between 6am and midnight only.

Please refer to the Specification document on the next page for more info

PLEASE SUBMIT THE FOLLOWING:

- A description of your proposed work detailing the ideas and concepts behind the work, an outline of any physical aspects (such as sound), the date and title
- A concise artist's resume of no more than 2 pages and up to 3 images and/or links to online video illustrating art practice. Please also include a contact phone number and email address in your submission. Social media handles and website links may also be useful although this is optional

Please submit Word, PDF, jpeg or avi files only

IMPORTANT NOTES TO MENTION:

- Only moving image submissions will be accepted due to the nature and specifications of the exhibition space.
- The moving image gallery is a public space, external to the main gallery. You may want to consider its diverse audience when selecting your chosen work.
- Submissions can include new or existing works. Please include exhibition history in your proposal if you have chosen an existing work that has been exhibited previously.
- Please indicate any scheduling preferences in your proposal, particularly if your work relates to a specific time of year or you intend to show the work elsewhere.
- Moving image works will be shown for 6-8 weeks at a time.

SUBMISSION DETAILS:

Applications close Friday 24 November 2023

Please email submissions or any pātai to rearwindow@dcc.govt.nz

Applicants will receive an initial email confirmation and an outcome by 22 December 2023

Please note our Rear Window Programme has limited spaces per year

2024

+64 3 474 3240 dpagmail@dcc.govt.nz
30 the Octagon DUNEDIN 9016
www.dunedin.art.museum
A Department of Dunedin City Council

ART
DUNEDIN PUBLIC ART GALLERY

MOVING IMAGE PROGRAMME

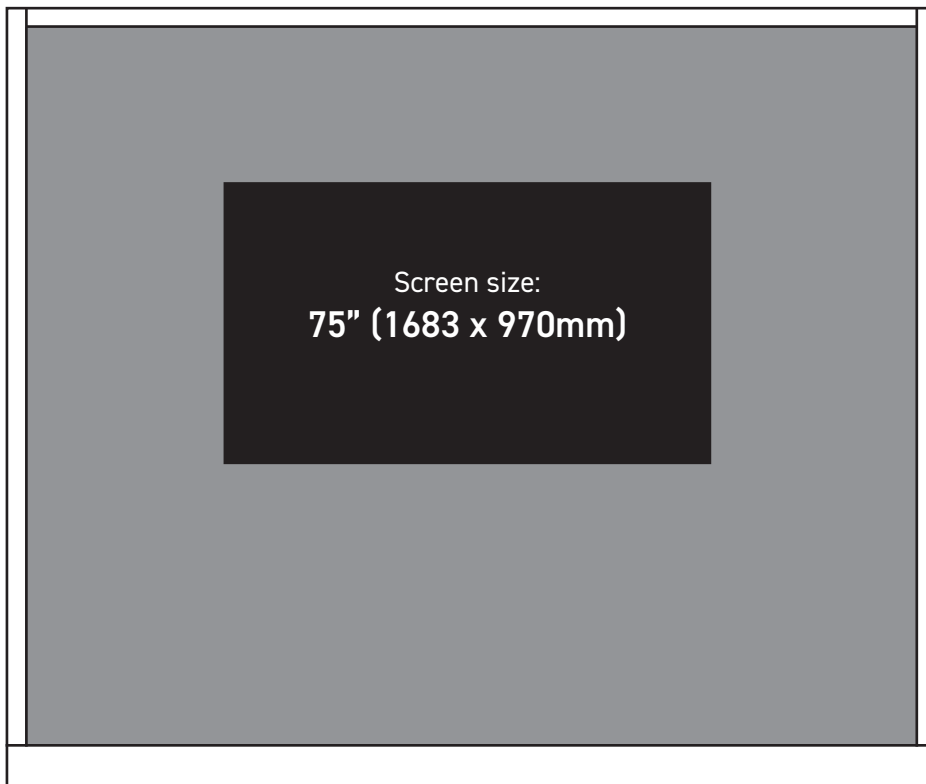

Window frame: 3238 x 2662 mmm

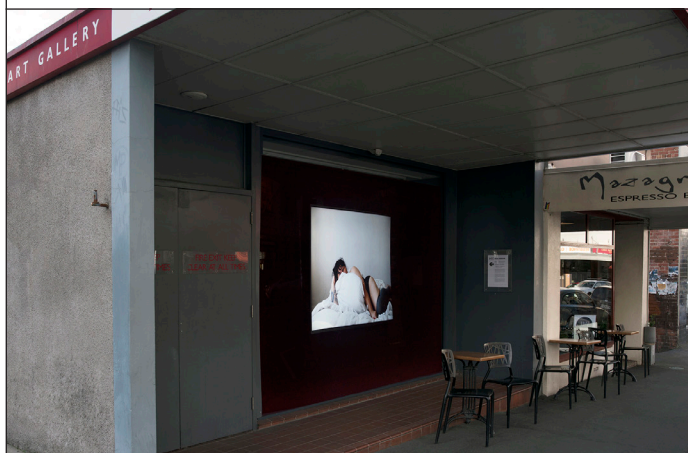

The Rear Window space is located in the city centre at 40 Moray Place, Dunedin.

Left: Natasha Matila-Smith **7 Minutes in Heaven** 2021. Installation view, 2022.

Right: Xin Cheng and Adam Ben-Dror **Making Like a Forest: Manawa Karioi** 2020. Installation view, 2022.